

DESCRIPTION

LaMaCo offer a wide range of rubber waterstop designed to be easily integrated into joints in concrete, providing a seal, to prevent the migration of water through the joint.

Designed to withstand long term movement, LaMaCo **Castjoint EE Swellable** are ideal for joints in bridges, water retaining and excluding structures and are manufactured to international standards.

Castjoint EE Swellable are available in 200mm, 250mm & 300 and 350mm widths and can be manufactured from natural, neoprene or hypalon rubber to suit your specifications.

A range of factory made and quality controlled intersections can be provided and they can be factory vulcanized to straight lengths eliminating some of the onsite vulcanizing. Hot and cold vulcanizing kits are available for the onsite joining requirements.

LaMaCo can provide training to your labour so vulcanizing can be performed without failures (the main cause of waterstop joint leakage). Please refer to our hot vulcanizing and cold bonding procedure instructions.

AREA OF APPLICATION

Water retaining

- Sewage treatment plants and water treatment plants
- Swimming pools
- Reservoirs and Water tank
- Dams and spillways and Diversion tunnels

Water excluding

- Basements area
- Tunnels
- Retaining walls
- Suspended slabs
- Pits
- Roof slabs

ADVANTAGES

- High Degree of elasticity to accommodate cyclic thermal movements
- High elongation to clear for subsidence and seismic movement
- Withstands high water pressure
- Hot vulcanized site joints



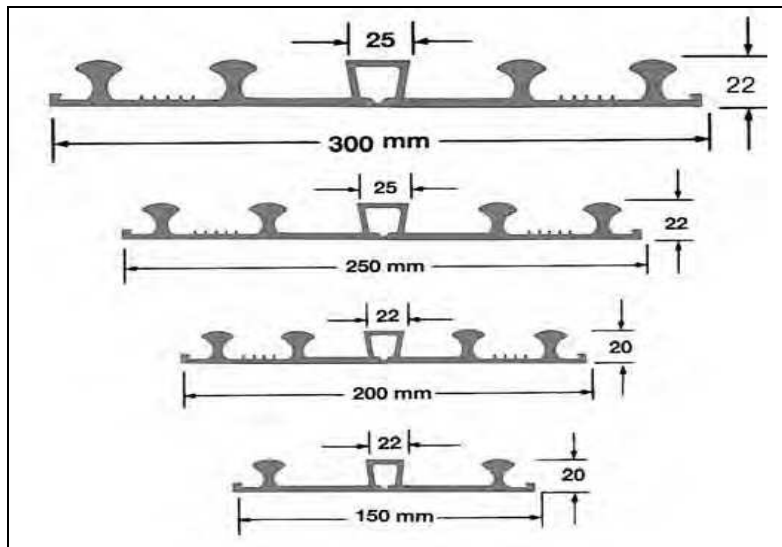

Model: **Castjoint EE Swellable**

Type of Application System: External Type Swellable Rubber Waterstop For Expansion Joint

Size of Width: 200mm **Castjoint EE Swellable 200**
 250mm **Castjoint EE Swellable 250**
 300mm **Castjoint EE Swellable 300**

Typical Properties

Item		Natural Rubber	Synthetic Rubber	Water Expansion Waterproof Line
Hardness (Shore A)		60±5	60±5	55±10
Tensile Strength (Mpa)	Before expansion	≥ 18	≥ 16	≥ 6
	After expansion	-	-	≥ 6
Elongation at break (%)		≥ 450	≥ 400	≥ 500
Constantly Compression Permanent Deformation(%)		≤ 36	≤ 35	-
		≤ 20	≤ 20	≤ 25
Brittle Temperature (%)		≤ -50	≤ -40	≤ -40
Hot Air Aging Test (70°C*72h)	change of hardness	≤ ±8	≤ ±8	≤ ±10
	reduce rate of breaking strength(%)	≤ 10	≤ 10	≤ 15
	reduce rate of breaking expansion(%)	≤ 20	≤ 20	≤ 25
Water Absorption Rate of Volume Expansion(%)		-	-	≥ 100
Adhesive Strength of Galvanized Sheet and Rubber (Mpa)		-	-	≥ 6

SITE JOINING**Hot Vulcanising Joining Procedures**

- Pre-heat the hot vulcaniser unit for approximately 30-45 minutes prior to placement of the **Castjoint EE Swellable** into it. The hot vulcaniser must be set at a temperature between 140-150 degree celcius to successful cure the rubber compounded joint.
- Cut each end of the **Castjoint EE Swellable** that are to be joined, square and straight.
- Wire brush up to 2" wide all around the **Castjoint EE Swellable** and on the ends to roughen the surface.
- Clean the **Castjoint EE Swellable** surface with solvent cleaser using a paint brush. Apply liberally up to 2" around the **Castjoint EE Swellable** and on the ends. Allow drying before the next step.
- Liberally apply 1 coat of LaMaCo Rubber Adhesive by brush up to 2" wide all around the waterstop and on the ends. Wait for adhesive to go tacky before the next step.
- Cut the rubber cover/compound with scissors into 2 pieces 1" wide and in length by the wide of the **Castjoint EE Swellable**. Place these pieces on each end on the rubber waterstop and press firmly into position. Now cut small pieces of compound that are similar sizes to trhe diameter of the outside dumbell section of the waterstop and firmly into position on each end of the rubber waterstop profile. If there is a centrebulb section to the rubber waterstop, then also cut a piece for each side and fit into position. Once this has been completed, firmly press the 2 pieces of rubber waterstop together at their ends.
- Now cut 1" wide section of rubber compound long enough so it can wrap around the **Castjoint EE Swellable**. This section must be centrally placed over the join and wrap fully around the rubber waterstop. The rubber waterstop join is now ready to be placed into the hot vulcaniser.
- Once the correct temperature has been achieved, then the joint is placed into position and the lid of the hot vulcaniser is clamped over the top of the **Castjoint EE Swellable** 30-40 minutes.
- Once the 30-40 minutes time frame has been achieved, unclamp the **Castjoint EE Swellable** and remove it from the hot vulcaniser. Allow the rubber waterstop to cool for about 20 minutes before any excessive movement is placed on the join.

COLD BONDING JOINING PROCEDURES

LaMaCo **Castjoint EE Swellable** can be cold bonded using our special Adhesive Kits but it is only recommended for construction joint applications. Refer to LaMaCo's cold bonding procedures which is available upon request.

Handling Precautions

Mandatory and recommended industrial hygiene procedures should be followed whenever our products are being handled and processed. For additional information please consult the corresponding product safety data sheets and the brochure "Hygienic Precautions for Handling Plastic Products"

The General Term & Conditions

All recommendations for use of our product, whether given by us in writing, verbally, or to be implied from the results of tests carried out by us are based on the current state of our knowledge. Notwithstanding any such recommendations the Buyer shall remain responsible for satisfying himself that the products as supplied by us are suitable for this intended process or purpose. Since we cannot control the application, use or processing of the products, we cannot accept responsibility therefore. The Buyer shall ensure that the intended use of the products will not infringe any third party's intellectual property rights. We warrant that our products are free from defects in accordance with and subject to our general conditions of supply.



LaMaCo System Sdn Bhd

407, Jalan Perusahaan 6, Taman Bandar Baru Mergong,
05150 Alor Setar, Kedah, Malaysia

Tel : +60-4-734 5555

Fax : +60-4-772 4444

Http : www.lamaco.com

Email : info@lamaco.com

IMPORTANT: While the information and data sheet contained in this promotional literature are presented in good faith and believed to be reliable, they do not constitute a part of our terms and conditions of sales unless specifically incorporated in our Order acknowledgement. Nothing herein shall be deemed to constitute a warranty, express or implied, that said information or data sheet are correct or that the products described are merchantable or fit for a particular purpose, or that said information, data sheet or products can be used without infringing patent of third parties.